

ZOOM    SIZED FOR PRINT

**REPLACEMENT**

1. REMOVE FRONT WHEEL

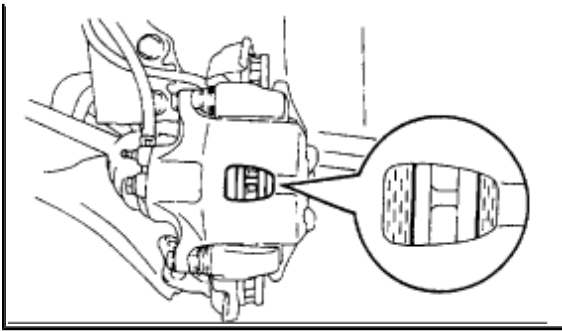



ZOOM

SIZED FOR PRINT

2. **INSPECT PAD LINING THICKNESS** Check the pad thickness through the caliper inspection hole and replace the pads if they are not within the specification. Minimum thickness: **1.0 mm (0.039 inch)**

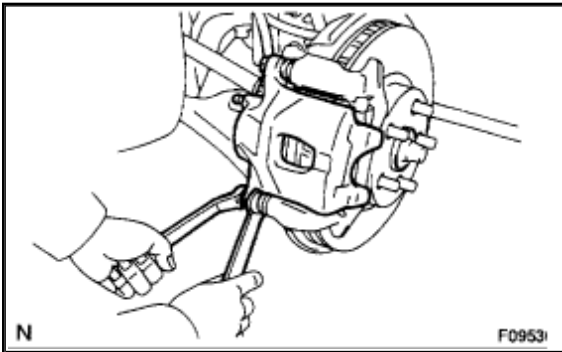

ZOOM

SIZED FOR PRINT

3. **LIFT UP CALIPER**
  - a. Hold the sliding pin and remove the bottom side installation bolt. **HINT:** Do not disconnect the flexible hose from the [brake caliper](#).
  - b. Lift up the caliper and suspend it securely.
4. **REMOVE 2 PADS WITH 4 ANTI-SQUEAL SHIMS AND PAD WEAR INDICATOR PLATES**
5. **REMOVE 2 PAD SUPPORT PLATE** **NOTICE:** The support plates can be used again provided that they have sufficient rebound, no deformation, cracks or wear, and have had all rust, dirt and foreign particles cleaned off.
6. **CHECK DISC THICKNESS AND RUNOUT**
7. **INSTALL PAD SUPPORT PLATES** Install the 2 pad support plates. **NOTICE:** Do not assemble the upper and lower pad support plates in reverse.
8. **INSTALL NEW PADS** **NOTICE:** When replacing worn pads, the anti-squeal shims and wear indicator plates must be replaced together with the pads.

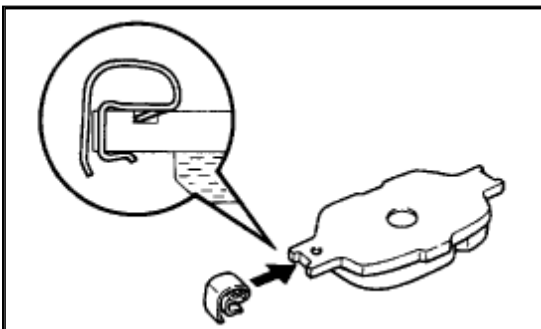

ZOOM

SIZED FOR PRINT

- a. 2ZZ-GE engine: Install a pad wear indicator plate on the each pad.
- b. 2ZZ-GE engine: Apply disc brake grease to both sides of each inner anti-squeal shim.
- c. 1ZZ-FE engine: Apply disc brake grease to both sides of the inner anti-squeal shim position outside.
- d. Install the 2 anti-squeal shims on each pad.
- e. Install the pads with the pad wear indicator plate facing upward. **NOTICE:** There should be no oil or grease adhering to the friction surfaces of the pads or the disc.

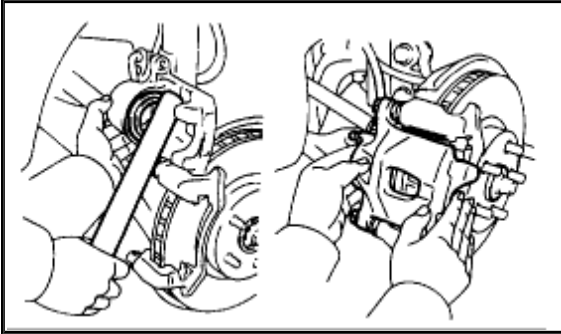

ZOOM

SIZED FOR PRINT

#### 9. INSTALL CALIPER

- a. Draw out a small amount of [brake fluid](#) from the reservoir.
- b. Press in the piston with a hammer handle or similar implement. **HINT:** If the piston is difficult to push in, loosen the bleeder plug and push in the piston while letting some [brake fluid](#) escape.
- c. Install the caliper.
- d. Hold the sliding pin and torque the installation bolts. Torque: **34 Nm (350 kgf-cm, 25 ft. lbs.)**

10. INSTALL FRONT WHEEL Torque: **103 Nm (1,050 kgf-cm, 76 ft. lbs.)**
11. DEPRESS BRAKE PEDAL SEVERAL TIMES
12. CHECK THAT FLUID LEVEL IS AT MAX LINE